



Part No. : **SG7N50W6-1500mA**

Features:

- High radiometric power per LED
- Very long operating life
(up to 100K hours)
- Low voltage DC operated
- More Energy Efficient than Incandescent
and most Halogen lamps
- Good color uniformity
- NO UV
- Superior ESD protection
- Easy installation with Screws
- High Heat dissipation Efficiency

Typical Applications:

- Reading lights(car,bus,aircraft)
- Portable(flashlight,bicycle)
- Automotive Exterior(Stop-Tail-Turn,
CHMSL,Mirror Side Repeat)
- Decorative/Entertainment
- Dental curing lights
- Uplighters/Downlighters
- Bollards/Security/Garden
- Cove/Undershelf/Task
- Indoor/Outdoor Commercial and Residential Architectural
- Automotive Ext(stop-Tail-Turn)
- Street Lamp

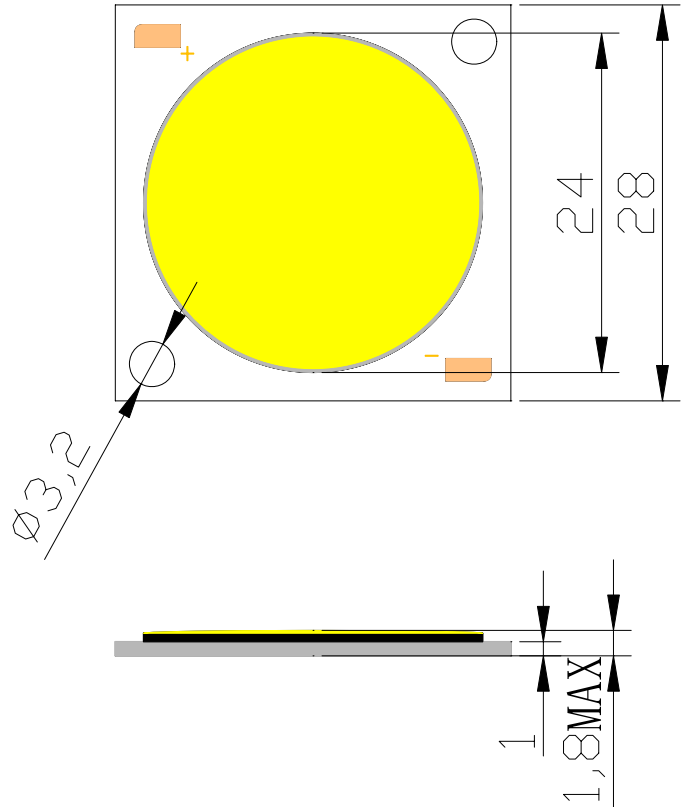

NOTE:

- All dimensions are millimeter.
- Tolerance is ± 0.1 mm unless otherwise noted.
- It is strongly recommended that the temperature of lead be not higher than 70°C .
- The appearance and specifications of the product may be modified for improvement without notice.



Part No.: **SG7N50W6 -1500mA**

Typical Radiation Pattern

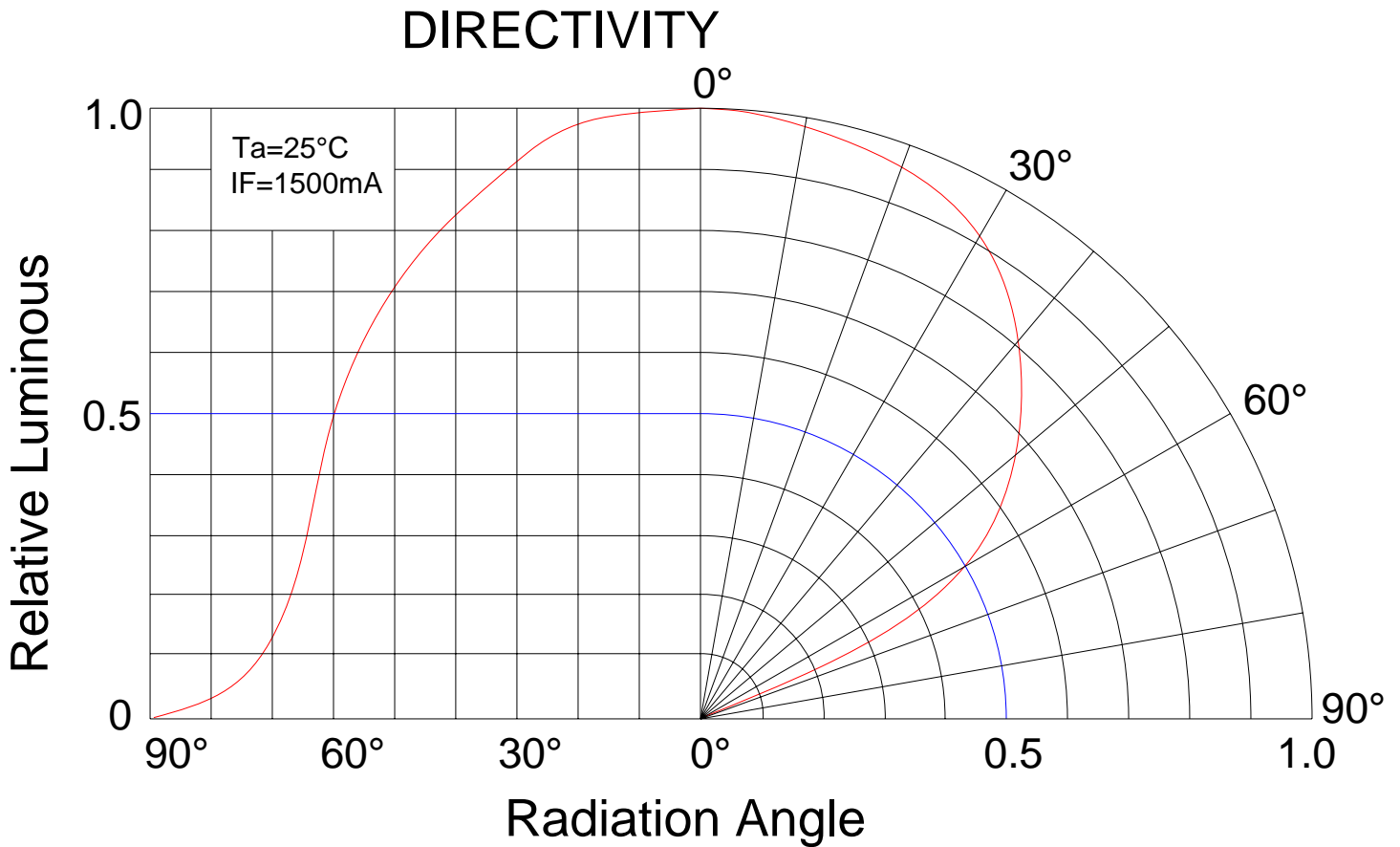

Absolute maximum ratings (Ta = 25°C)

Parameter	Symbol	Test Condition	Value		Unit
			Min.	Max.	
DC Forward Current	IF	----	----	1800	mA
Peak Pulse Current	Ipeak	Duty=1/10 1kHz	----	1900	mA
Power Dissipation	Pd	----	----	60	W
LED Junction Temperature	Tj	----	----	105	°C
Operating Temperature	Topr	----	-25	+85	°C
Storage Temperature	Tstr	----	-40	+100	°C
ESD Sensitivity	----	HBM	8000	----	V
Soldering Temperature	----	----	220°C for 5 Seconds max		



Part No. :SG7N50W6 -1500mA

Electrical and optical characteristics (Ta = 25°C)

Parameter	Symbol	Test Condition	Value			Unit	
			Min.	Typ.	Max.		
Forward Voltage	VF	IF = 1500mA		31		V	
Luminous Flux	Φv			5500	----	lm	
Viewing Angle	2θ 1/2			----	120	----	Deg.
Color Temperature	CCT			5000	-----	6500	K
Thermal Resistance	Rj	-----		0.4		°C/W	

Luminous Flux Bins (Ta = 25°C)

Unit: lm

Bin	V2	W2	X2
Min	5000	5500	6000
Max	5500	6000	6500

Chromaticity Coordinates Ranks(IF=1500mA Ta=25°C)

Bin	x1	y1	x2	y2	x3	y3	x4	y4
PT1	0.3384	0.3650	0.3381	0.3550	0.3461	0.3617	0.3469	0.3717
PT2	0.3381	0.3550	0.3378	0.3451	0.3453	0.3518	0.3461	0.3617
PT3	0.3378	0.3451	0.3374	0.3352	0.3444	0.3418	0.3453	0.3518
PT4	0.3374	0.3352	0.3371	0.3252	0.3436	0.3318	0.3444	0.3418
PV1	0.3300	0.3584	0.3302	0.3484	0.3381	0.3550	0.3384	0.3650
PV2	0.3302	0.3484	0.3303	0.3384	0.3378	0.3451	0.3381	0.3550
PV3	0.3303	0.3384	0.3304	0.3285	0.3374	0.3352	0.3378	0.3451
PV4	0.3304	0.3285	0.3306	0.3185	0.3371	0.3252	0.3374	0.3352
PW1	0.3236	0.3534	0.3242	0.3434	0.3302	0.3484	0.3300	0.3584
PW2	0.3242	0.3434	0.3247	0.3335	0.3303	0.3384	0.3302	0.3484
PW3	0.3247	0.3335	0.3253	0.3235	0.3304	0.3285	0.3303	0.3384
PW4	0.3253	0.3235	0.3258	0.3136	0.3306	0.3185	0.3304	0.3285
PX1	0.3173	0.3484	0.3182	0.3385	0.3242	0.3434	0.3236	0.3534
PX2	0.3182	0.3385	0.3191	0.3286	0.3247	0.3335	0.3242	0.3434
PX3	0.3191	0.3286	0.3201	0.3186	0.3253	0.3235	0.3247	0.3335
PX4	0.3201	0.3186	0.3210	0.3086	0.3258	0.3136	0.3253	0.3235
PY1	0.3109	0.3434	0.3122	0.3335	0.3182	0.3385	0.3173	0.3484
PY2	0.3122	0.3335	0.3135	0.3236	0.3191	0.3286	0.3182	0.3385
PY3	0.3135	0.3236	0.3149	0.3136	0.3201	0.3186	0.3191	0.3286
PY4	0.3149	0.3136	0.3162	0.3037	0.3210	0.3086	0.3201	0.3186



Part No. : SG7N50W6 -1500mA

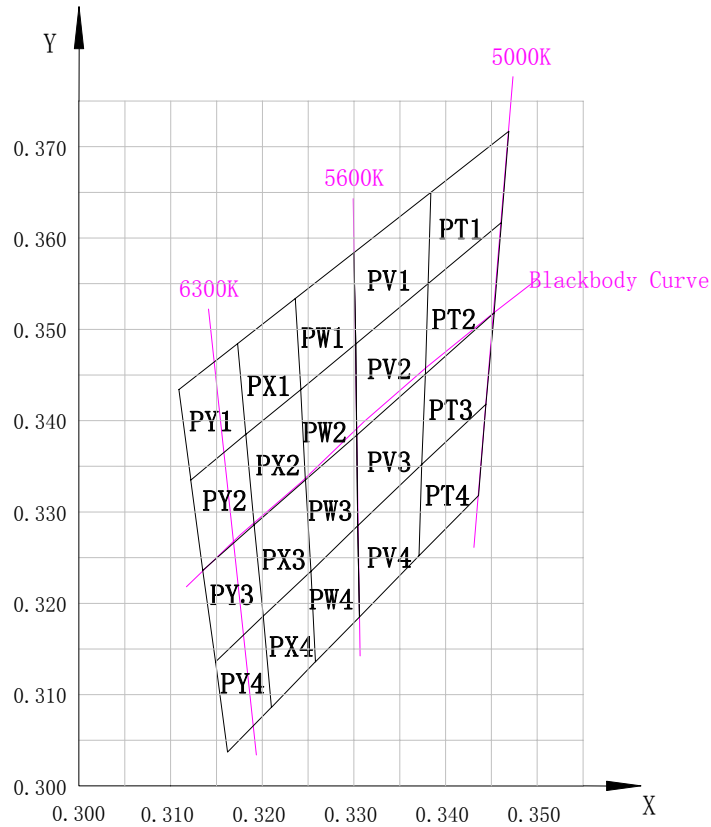

Note

1. Flux is measured with an accuracy of $\pm 15\%$
2. Chromaticity Coordinates (x,y) is measured with an accuracy of ± 0.01
3. Forward Voltage is measured with an accuracy of $\pm 2\%$
4. It is strongly recommended that the temperature of lead be not higher than 70°C



Part No. : SG7N50W6 -1500mA

Typical electrical/optical characteristic curves $T_J=25^{\circ}\text{C}$

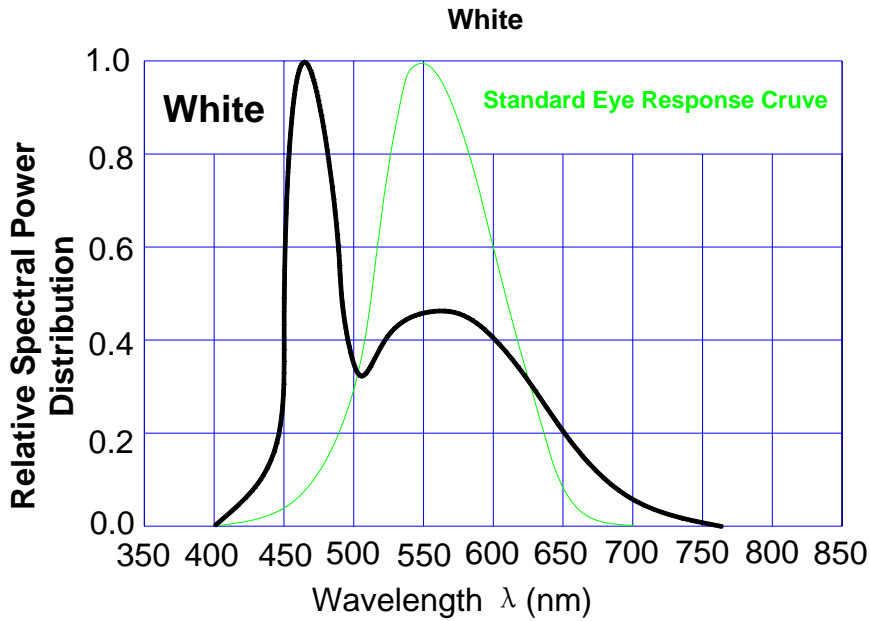

Typical electrical/optical characteristic curves:

Fig.1 Forward Current(mA) Vs. Forward Voltage(V)

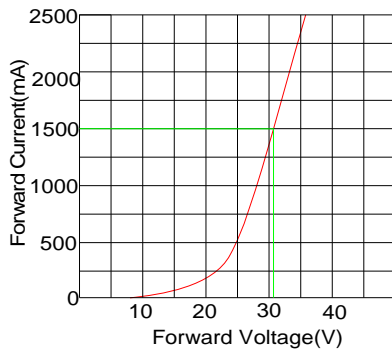

Fig.2 Relative Intensity Vs Forward Current (mA)

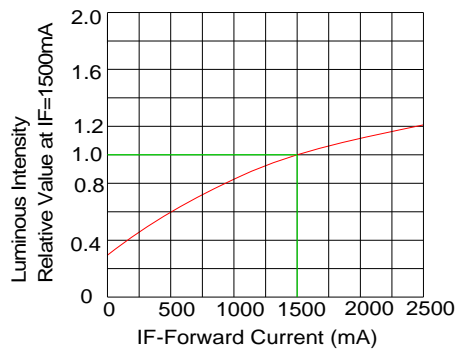

Fig.3 Forward Current Vs Ambient Temperature

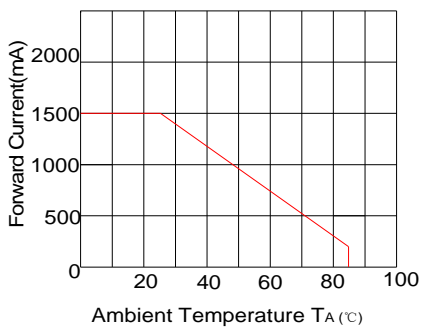
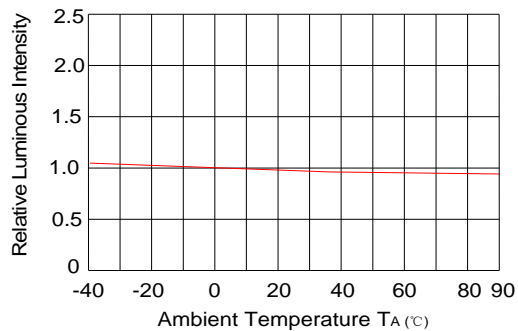

Fig.4 Relative Intensity Vs. Ambient Temperature





Part No. : **SG7N50W6 -1500mA**

Recommended installation screw pitch

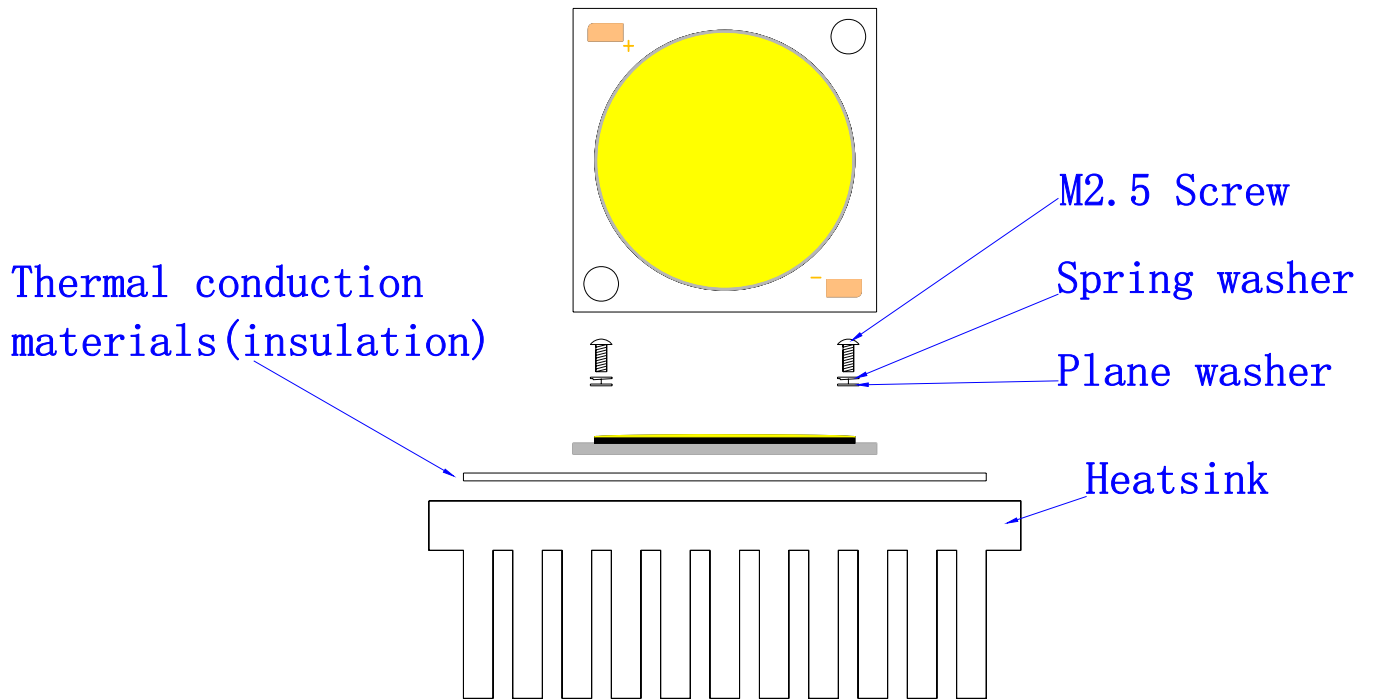

If you can not solve the heat problem, the product will destroy easily. Suggest that the surface of the heat sink is $35\text{cm}^2/\text{W}$