

**Part No.: S12KG2C**



**Features:**

- Highest Flux Pure Green
- High reliability and Very long operating life (up to 100K hours)
- Low voltage DC operated
- More Energy Efficient than Incandescent and most Halogen lamps
- NO UV
- Superior ESD protection

**Typical Applications:**

- Decorative
- Portable(flashlight,bicycle)
- Automotive Exterior(Stop-Tail-Turn, CHMSL,Mirror Side Repeat)
- 

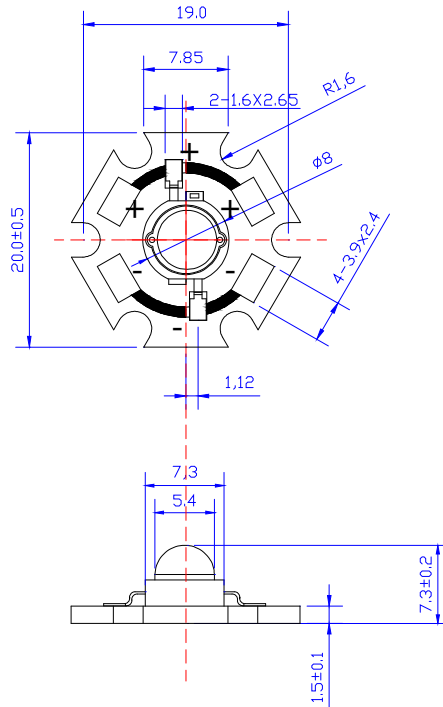

**NOTE:**

- All dimensions are millimetres.
- Tolerance is  $\pm 0.1$ mm unless otherwise noted

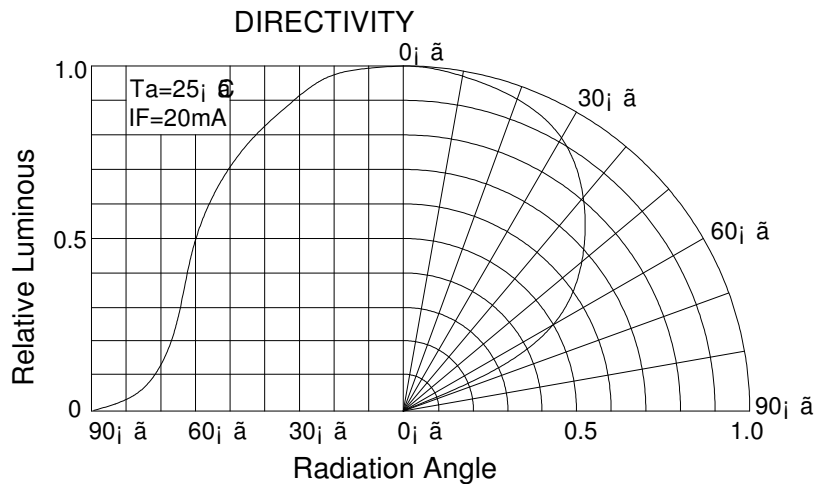



**Part No.: S12KG2C**

**Absolute maximum ratings (Ta = 25°C)**

Parameter	Symbol	Test Condition	Value		Unit
			Min.	Max.	
DC Forward Current	IF	----	----	350	mA
Peak Pulse Current	Ipeak	Duty=0.1mS, 1kHz	----	500	mA
Power Dissipation	Pd	----	----	1.4	W
LED Junction Temperature	Tj	----		120	°C
Operating Temperature	Topr	----	-25	+100	°C
Storage Temperature	Tstr	----	-40	+120	°C
ESD Sensitivity	---	HBM	8000	---	V
Soldering Temperature	---	-----	260°C for 5 Seconds max		

**Electrical and optical characteristics (Ta = 25°C)**

Parameter	Symbol	Test Condition	Value			Unit
			Min.	Typ.	Max.	
Forward Voltage	VF	IF = 350mA	----	3.5	4.0	V
Luminous Flux	Φv	IF = 350mA	15	18	20	lm
Viewing Angle	2 θ 1/2	IF = 350mA	----	120	----	Deg.
Dominant Wavelength	λd	IF = 350mA	520	----	530	nm

**Luminous Flux Bins (Ta = 25°C)**

**Unit:lm**

Bin	B	C	D	E	F	G
Min	5	10	15	20	25	30
Max	10	15	20	25	30	40

**Dominant Wavelength- λd (Ta = 25°C)**

**Unit: nm**

Bin	B	M	P	N		
Min	500	510	520	530		
Max	510	520	530	540		



**Part No.: S12KG2C**

**Typical electrical/optical characteristic curves:**

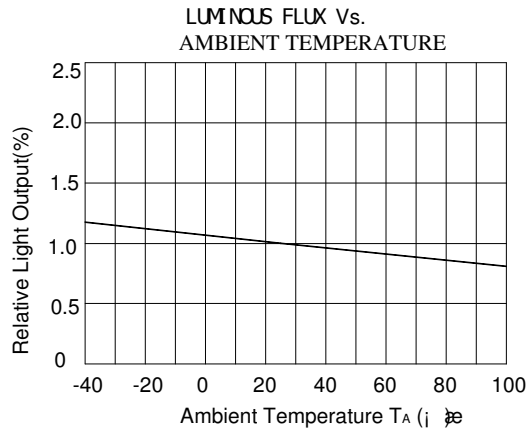
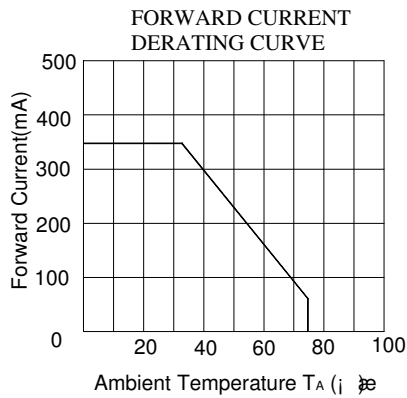
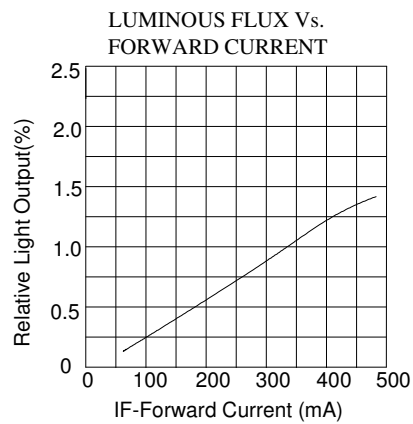
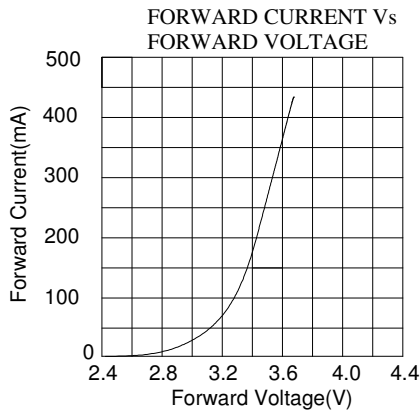

**525/30**

