



Hebei I.T. (Shanghai) Co., Ltd.
Technical Data Sheet
Top View LED

• Customer:

Technical Data Sheet

PN: [PLCC6XRGBCT](#)

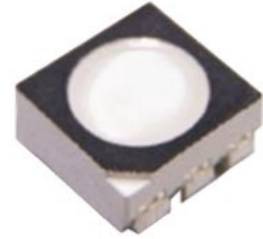

Contents

- 1.Features
- 2.Applications
- 3.Package dimensions
- 4.Absolute maximum rating
- 5.Electrical optical characteristics
- 6.BIN range
- 7.Soldering pad dimensions
- 8.Soldering conditions
- 9.Package tape specifications
- 10.Typical electro-optical characteristics curves
- 11.Reliability
- 12.Cautions
- 13.Notes



Customer confirm	Approved by	Checked by	Issued by



Hebei I.T. (Shanghai) Co., Ltd.

Technical Data Sheet

Top View LED

Part No.	PLCC6XRGBCT		
Emitted Color	RGB	Face Color	Black
Chip Material	AlGaInP/InGaN	Package	PPA

◆ Features:

- Compatible with automatic placement equipment
- Compatible with reflow solder process
- Low power consumption and wide viewing angle
- This product doesn't contain restriction Substance, comply ROHS standard.

◆ Applications:

- Automotive and Telecommunication
- Flat backlight for LCD ,switch and symbol in telephone and fax
- General use for indicators
- Indoor displays

◆ Package Dimensions:

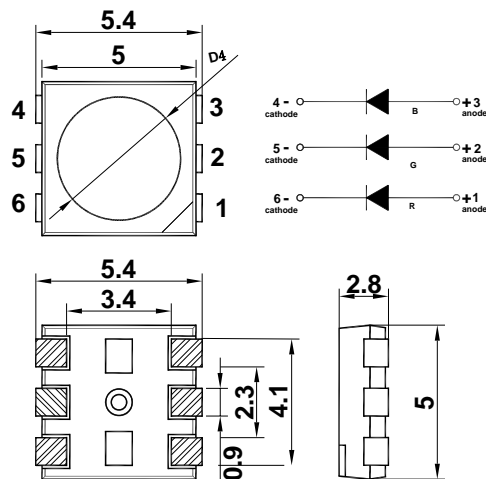

Unit:mm
Tolerance: $\pm 0.2\text{mm}$

Electrodes: Ag Plating
Encapsulating Resin: Epoxy.



Hebei I.T. (Shanghai) Co., Ltd.

Technical Data Sheet

Top View LED

◆ Absolute Maximum Rating (Ta=25°C)

Parameter	Symbol	Max.	Unit	
Power Dissipation	P _M	R	69	Mw
		G	105	Mw
		B	105	Mw
Pulse Forward Current	I _{FP}	100	mA	
DC Forward Current	I _F	30	mA	
Reverse Voltage	V _R	5	V	
Operating Temperature Range	Topr	-30°C ~ 85°C	°C	
Storage Temperature Range	Tstg	-40°C ~ 100°C	°C	

* I_{FP} condition: pulse width ≤ 1ms ,duty cycle ≤ 1/10

◆ Electrical Optical Characteristics (Ta=25°C)

Parameter	Symbol	Min	Typ.	Max.	Unit	Test Condition	
Luminous Intensity	I _V	R	600	--	900	mcd	I _F =20mA
		G	1200	--	1585	mcd	I _F =20mA
		B	240	--	320	mcd	I _F =20mA
Forward Voltage	V _F	R	1.8	--	2.3	V	I _F =20mA
		G	2.9	--	3.5	V	I _F =20mA
		B	2.9	--	3.5	V	I _F =20mA
Dominate Wavelength	λ _D	R	618	--	628	nm	I _F =20mA
		G	520	--	530	nm	I _F =20mA
		B	465	--	475	nm	I _F =20mA
Reverse Current	I _R	--	--	10	uA	V _R =5V	
Viewing Angle	2θ _{1/2}	--	120	--	Deg.	I _F =20mA	

Notes: 1. Tolerance of Luminous Intensity ± 10%.

2. Tolerance of Forward Voltage ± 0.05V.

3. Tolerance of Dominate Wavelength ± 0.1nm.

4. Optical characteristic is measured by HB's equipment.



Hebei I.T. (Shanghai) Co., Ltd.

Technical Data Sheet

Top View LED

◆ Soldering Pad Dimensions:

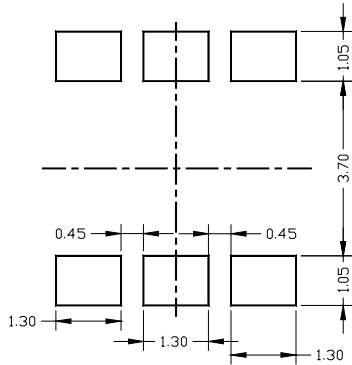

Unit:mm
Tolerance: ± 0.2 mm

◆ Soldering Conditions (Maximum allowable soldering conditions)

	Reflow Soldering		Hand Soldering	
	Lead Solder	Lead-free Solder	Temperature	Soldering time
Pre-heat	120 ~ 150°C	180 ~ 200°C	350°C Max. 3 sec. Max. (one time only)	
Pre-heat time	120 sec. Max.	120 sec. Max.		
Peak temperature	240°C Max.	260°C Max.		
Soldering time	10 sec. Max.	10 sec. Max.		
Condition	refer to Temperature - profile ①.	refer to Temperature - profile ②. (N ₂ reflow is recommended.)		

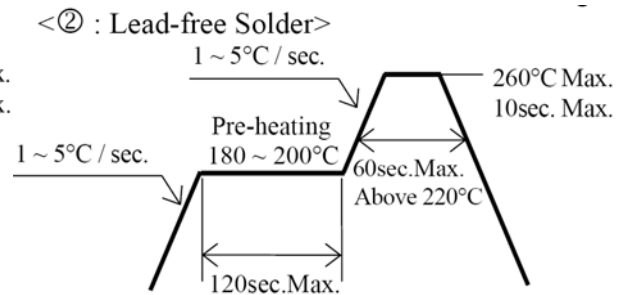
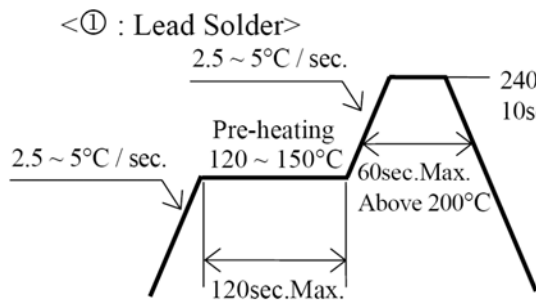

- Reflow soldering should not be done more than two times.
- Do not stress its resin while soldering.
- After soldering, do not warp the circuit board.
- Pay attention to electrostatic (ESD) .



Hebei I.T. (Shanghai) Co., Ltd.

Technical Data Sheet

Top View LED

◆ Package Tape Specifications: (600±1 pcs/Reel)

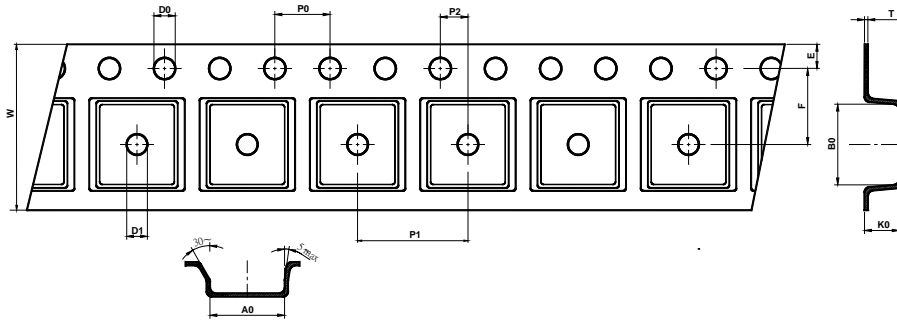

Unit:mm

symbol	A0	B0	K0	P0	P1	P2	T
spec	5.41±0.10	5.78±0.10	3.10±0.10	4.00±0.10	8.00±0.10	2.00±0.05	0.25±0.05
symbol	E	F	D0	D1	W	10P0	
spec	1.75±0.10	5.50±0.05	1.55±0.05	1.5MIN	12.0±0.30	40.0±0.20	

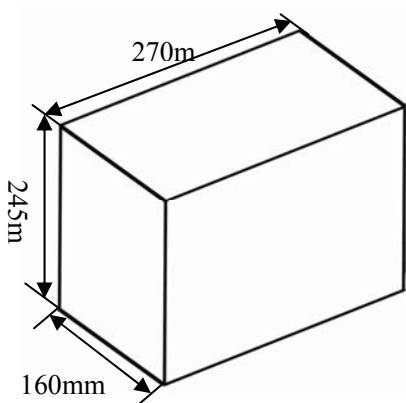
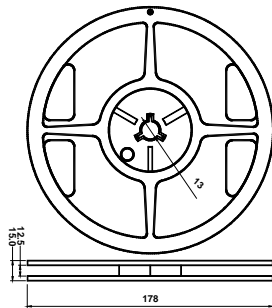

12 Reels in one Box

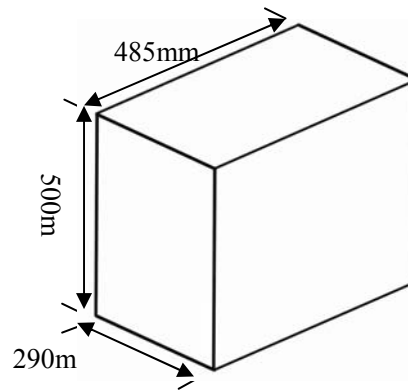

6 Boxes in one Carton



Hebei I.T. (Shanghai) Co., Ltd.

Technical Data Sheet

Top View LED

◆ Typical Electro-Optical Characteristics Curves:

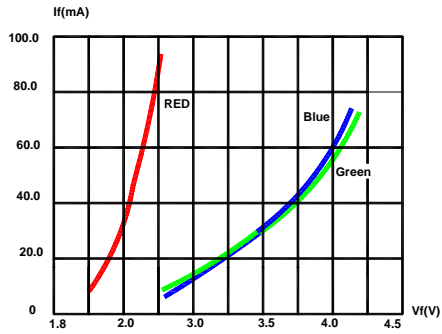

Fig.1 Forward Current vs. Forward Voltage

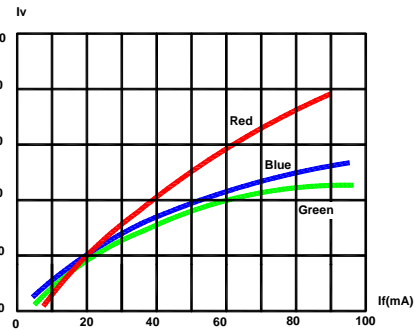

Fig.2 Relative Luminous Intensity vs. Forward Current

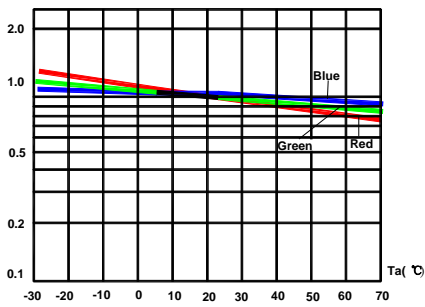

Fig.5 Relative Luminous Intensity vs. Ambient Temperature

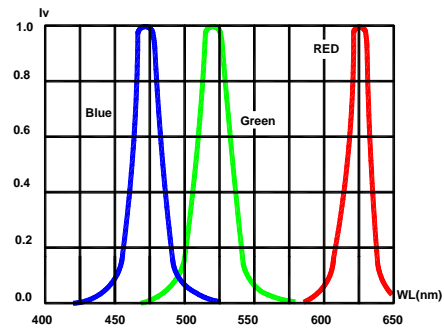

Fig.4 Relative Luminous Intensity vs. Wavelength

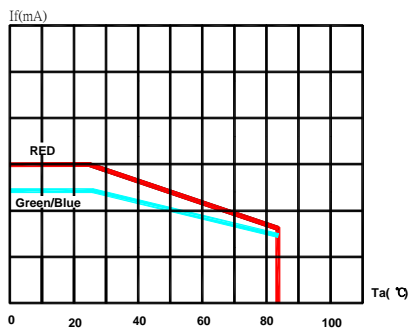
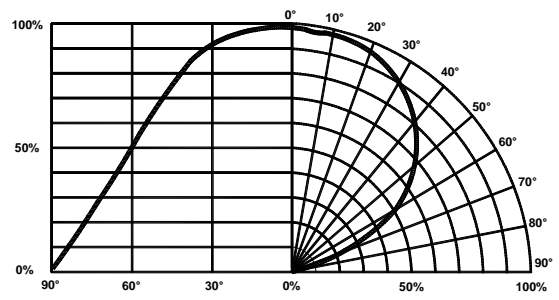

Fig.6 Maximum Forward Current vs. Ambient Temperature



Relative Luminous Intensity vs. Radiation Angle



Hebei I.T. (Shanghai) Co., Ltd.

Technical Data Sheet

Top View LED

◆ Reliability

(1) Test Items and Conditions

Test Item	Standard Test Method	Test Conditions	Note	Number of Damaged
Reflow Soldering	JEITA ED-4701 300 301	A. $T_A=230\pm 5^{\circ}\text{C}$ TIME=30-60S B. $T_A=240\pm 5^{\circ}\text{C}$ TIME=110-120S C. $T_A=260\pm 5^{\circ}\text{C}$ TIME=10 \pm 1S D. $T_A=230\pm 5^{\circ}\text{C}$ TIME=30-60S	1 time	0/50
High Temperature Storage	JEITA ED-4701 200 201	$T_A=100\pm 5^{\circ}\text{C}$	1000 Hrs	0/50
Low Temperature Storage	JEITA ED-4701 200 202	$T_A=-40\pm 5^{\circ}\text{C}$	1000 Hrs	0/50
Temperature Humidity Storage	JEITA ED-4701 100 103	$T_A=85\pm 5^{\circ}\text{C}$, RH=90%RH	1000 Hrs	0/50
Thermal Shock Test	JEITA ED-4701 300 307	-40 $^{\circ}\text{C}$ ~ 100 $^{\circ}\text{C}$ 15min 15 Second 15 min	100 Cycles	0/50
Temperature Cycling Test	JEITA ED-4701 100 105	-40 $^{\circ}\text{C}$ ~ 25 $^{\circ}\text{C}$ ~100 $^{\circ}\text{C}$ ~25 $^{\circ}\text{C}$ 30min 15min 30min 15min	100 Cycles	0/50
Operating Life Test	MIL-STD-750:1026 MIL-STD-883:1005 JIS C 7021 :B-1	$T_A=25^{\circ}\text{C}$ $I_F=20\text{mA}$	1000 Hrs	0/50

(2) Criteria of judging the damage

Item	Symbol	Test Conditions	Criteria for Judgment	
			Min.	Max.
Forward Voltage	V_F	$I_F=20\text{mA}$	---	Initial Data $\times 1.1$
Luminous Intensity	I_V	$I_F=20\text{mA}$	Initial Data $\times 0.8$	---
Reverse Current	I_R	$V_R=5\text{V}$	---	$\leq 50\mu\text{A}$
Wave length	$\lambda D/\lambda P$	$I_F=\text{Test Current}$	/	Initial Data $\pm 2\text{nm}$
Appearance	/	View check	No mechanical damage	



Hebei I.T. (Shanghai) Co., Ltd.

Technical Data Sheet

Top View LED

◆ Cautions

1、 Package

When moisture is absorbed into the package it may vaporize and expand during soldering. There is a possibility that this can cause exfoliation of the contacts and damage to the optical characteristics of the LEDs. So the moisture proof package is used to keep moisture to a minimum in the package.

2、 Storage

Before opening the package: The LEDs should be kept at 5~30°C and 60%RH or less. The LEDs should be used within a year.

After opening the package: The LED must be used within 24 hours, else should be kept at 5~30°C and 30% RH or less. The LEDs should be used within 7days after opening the package. If unused LEDs remain, they should be stored in moisture proof packages, recommended to return the LEDs to the original moisture proof bag and to reseal the moisture proof bag again.

If the LEDs have exceeded the storage time, baking treatment should be performed more than 24 hours at $60 \pm 5^\circ\text{C}$.

3、 Soldering Iron

Each terminal is to the tip of soldering iron temperature less than 300°C for 3 seconds within once in less than the soldering iron capacity 25 W. Leave two seconds and more internally, and do soldering of each terminal. Be careful because the damage of the product is often started at the time of the hand solder.

4、 Repairing

Repairing should not be done after the LEDs have been soldered. When repairing is unavoidable, a double-head soldering iron should be used (as below figure). It should be confirmed beforehand whether the characteristics of the LEDs will or will not be damaged by repairing.

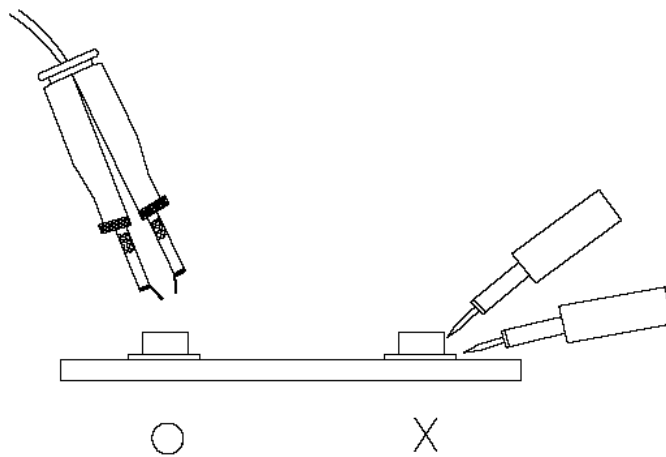

5、 The LED electrode sections are comprised of a gold plated. The gold surface may be affected by environments which contain corrosive gases and so on. Please avoid conditions which may cause the LED to corrode or discolor. This corrosion or discoloration may cause difficulty during soldering operations. It is recommended that the User use the LEDs as soon as possible.

6、 Please avoid rapid transitions in ambient temperature, especially in high humidity environments where condensation can occur.



Hebei I.T. (Shanghai) Co., Ltd.

Technical Data Sheet

Top View LED

7、 Static Electricity

7.1、 These products are sensitive to static electricity charge, and users are required to handle with care. Particularly, if an current and or voltage which exceeds the Absolute Maximum Rating of Products is applied, the overflow in energy may cause damage to, or possibly result in electrical destruction of, the Products. The customer is requested to take adequate countermeasures against static electricity charge and surge when handling Products.

7.2、 Proper grounding of Products , use of conductive mat, conductive working uniform and shoes, and conductive containers are effective against static electricity and surge.

7.3、 Ground low-resistance areas where the product contacts, such as metal surfaces of the work platform, with a conductive mat (surface resistance 10^6 - $10^8 \Omega$).

7.4、 A tip of soldering iron is requested to be grounded. An ionizer should also be installed where risk of static generation is high.

◆ Notes:

1、 Above specification may be changed without notice. We will reserve authority on material change for above specification.

2、 When using this product, please observe the absolute maximum ratings and the instructions for the specification sheets. We assume no responsibility for any damage resulting from use of the product which does not comply with the instructions included in the specification sheets.