



Hebei I.T. (Shanghai) Co., Ltd.

Technical Data Sheet

Top View LED

Part No: PLCC2W6-0.1W

Part No.	PLCC2W6-0.1W		
Emitted Color	Dominant White	Face Color	White
Chip Material	InGaN/GaN	Package	PPA

◆ Features:

Compatible with automatic placement equipment

Compatible with reflow solder process

Low power consumption and wide viewing angle

This product doesn't contain restriction Substance, comply ROHS standard.

◆ Applications:

Automotive and Telecommunication

Flat backlight for LCD ,switch and symbol in telephone and fax

General use for indicators

Indoor lighting

◆ Package Dimensions:

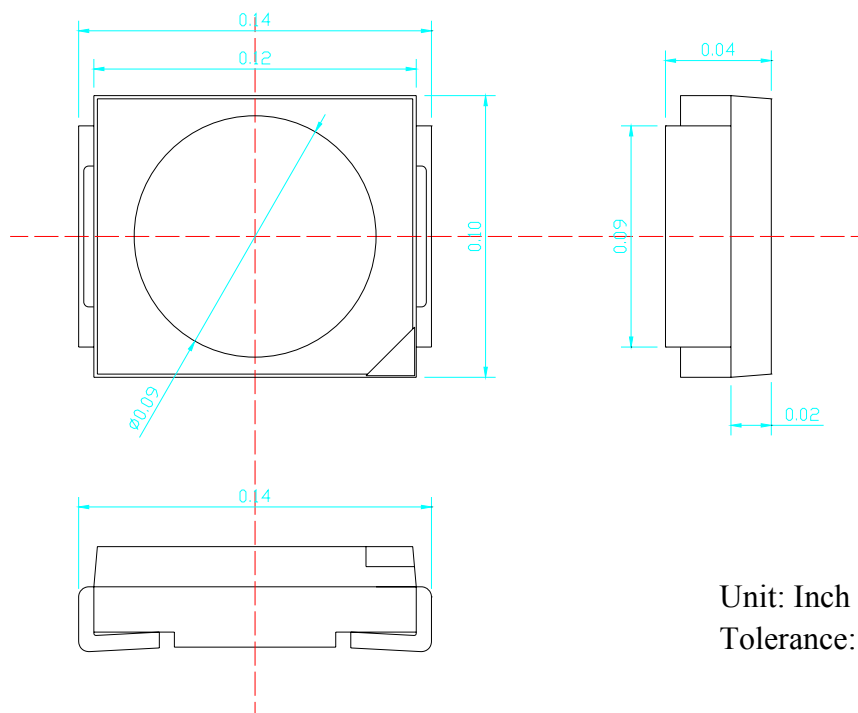

Unit: Inch

Tolerance: ± 0.01 inch

Electrodes: Ag Plating

Encapsulating Resin: Silicone with phosphor



Hebei I.T. (Shanghai) Co., Ltd.

Technical Data Sheet

Top View LED

Part No: PLCC2W6-0.1W

◆ Absolute Maximum Rating (Ta=25°C)

Parameter	Symbol	Max.	Unit
Power Dissipation	P_M	105	Mw
Pulse Forward Current	I_{FP}	100	mA
DC Forward Current	I_F	30	mA
Reverse Voltage	V_R	5	V
Operating Temperature Range	Topr	-30°C ~ 85°C	°C
Storage Temperature Range	Tstg	-40°C ~ 100°C	°C

* I_{FP} condition: pulse width $\leq 1ms$,duty cycle $\leq 1/10$

◆ Electrical Optical Characteristics (Ta=25°C)

Parameter	Symbol	Min	Typ.	Max.	Unit	Test Condition
Luminous Intensity	I_V	2790	--	--	mcd	$I_F=30mA$
Luminous Flux	Φ	9.0	--	--	lm	$I_F=30mA$
Correlated Color Temperature	CCT	5000	--	7000	K	$I_F=30mA$
Forward Voltage	VF	2.9	--	3.3	V	$I_F=30mA$
Color Rendering Index	Ra	70			--	$I_F=30mA$
Reverse Current	IR	--	--	10	uA	$V_R=5V$
Spectral Line Half Width	$\Delta \lambda$	--	30	--	nm	$I_F=30mA$
Viewing Angle	$2\theta_{1/2}$	--	120	--	Deg.	$I_F=30mA$

Notes: 1.Tolerance of Luminous Intensity $\pm 10\%$.

2.Tolerance of CCT $\pm 150K$.

3.Tolerance of Forward Voltage $\pm 0.05V$.

4.Optical characteristic is measured by HB's equipment.



Hebei I.T. (Shanghai) Co., Ltd.
Technical Data Sheet
Top View LED

Part No: PLCC2W6-0.1W

◆ BIN range

Forward voltage (tolerance is $\pm 0.05V @ I_F=30mA$):

BIN CODE	Min.(V)	Max. (V)
G1	2.9	3.1
H1	3.1	3.3
J1	3.3	3.5

Luminous intensity (tolerance is $\pm 10% @ I_F=30mA$):

BIN CODE	Min.(lm)	Max. (lm)	Choice
MG0	9	11	<input type="checkbox"/> Purchase
MH0	11	13	<input type="checkbox"/> Purchase
MG1	10	12	<input type="checkbox"/> Purchase
MH1	12	14	<input type="checkbox"/> Purchase

Chromaticity Coordinates & Bin grading diagram($I_F=30mA$):

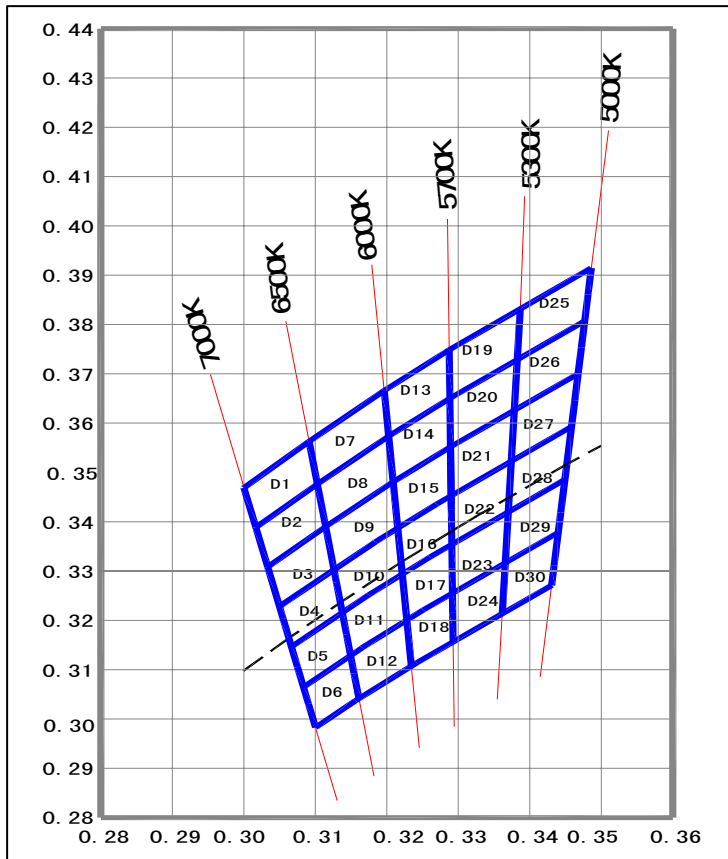

Color Bin Choice

Bin Code	CCT Range

Color Rendering Index Choice

Ra	Choice
>70	<input type="checkbox"/> Purchase
>80	<input type="checkbox"/> Purchase

Please confirm Bin range and Fax back this page to HB



Hebei I.T. (Shanghai) Co., Ltd.

Technical Data Sheet

Top View LED

Part No: PLCC2W6-0.1W

Bin range of Chromaticity Coordinates (tolerance is $\pm 0.005 @ I_F=30mA$):

Code	CCT (K)	X	Y	Code	CCT (K)	X	Y
D01	6500~7000	0.3000	0.3469	D02	65000~7000	0.3017	0.3389
		0.3091	0.3563			0.3103	0.3476
		0.3103	0.3476			0.3114	0.3390
		0.3017	0.3389			0.3033	0.3308
D03	6500~7000	0.3033	0.3308	D04	6500~7000	0.3050	0.3227
		0.3114	0.3390			0.3126	0.3303
		0.3126	0.3303			0.3138	0.3216
		0.3050	0.3227			0.3067	0.3146
D05	6500~7000	0.3067	0.3146	D06	6500~7000	0.3083	0.3065
		0.3138	0.3216			0.3149	0.3129
		0.3149	0.3129			0.3161	0.3041
		0.3083	0.3065			0.3100	0.2983
D07	6000~6500	0.3091	0.3563	D08	6000~6500	0.3103	0.3476
		0.3196	0.3666			0.3203	0.3574
		0.3203	0.3574			0.3209	0.3481
		0.3103	0.3476			0.3114	0.3390
D09	6000~6500	0.3114	0.3390	D10	6000~6500	0.3126	0.3303
		0.3209	0.3481			0.3215	0.3387
		0.3215	0.3387			0.3222	0.3294
		0.3126	0.3303			0.3138	0.3216
D11	6000~6500	0.3138	0.3216	D12	6000~6500	0.3149	0.3129
		0.3222	0.3294			0.3228	0.3200
		0.3228	0.3200			0.3234	0.3107
		0.3149	0.3129			0.3161	0.3041
D13	5700~600	0.3196	0.3666	D14	5700~6000	0.3203	0.3574
		0.3287	0.3748			0.3288	0.3650
		0.3288	0.3650			0.3289	0.3552
		0.3203	0.3574			0.3209	0.3481
D15	5700~6000	0.3209	0.3481	D16	5700~6000	0.3215	0.3387
		0.3289	0.3552			0.3290	0.3453
		0.3290	0.3453			0.3291	0.33354
		0.3215	0.3387			0.3222	0.3294
D17	5700~6000	0.3222	0.3294	D18	5700~6000	0.3228	0.3200
		0.3291	0.3354			0.3292	0.3255
		0.3292	0.3255			0.3293	0.3156
		0.3228	0.3200			0.3234	0.3107



Hebei I.T. (Shanghai) Co., Ltd.

Technical Data Sheet

Top View LED

Part No: **PLCC2W6-0.1W**

Code	CCT (K)	X	Y	Code	CCT (K)	X	Y
D19	5300~5700	0.3287	0.3748	D20	5300~5700	0.3288	0.3650
		0.3387	0.3832			0.3382	0.3729
		0.3382	0.3729			0.3378	0.3626
		0.3288	0.3650			0.3289	0.3552
D21	5300~5700	0.3289	0.3552	D22	5300~5700	0.3290	0.3453
		0.3378	0.3626			0.3374	0.3523
		0.3374	0.3523			0.3370	0.3420
		0.3290	0.3453			0.3291	0.3554
D23	5300~5700	0.3291	0.3554	D24	5300~5700	0.3292	0.3255
		0.3370	0.3420			0.3366	0.3317
		0.3366	0.3317			0.3362	0.3214
		0.3292	0.3255			0.3293	0.3156
D25	5000~5300	0.3387	0.3832	D26	5000~5300	0.3382	0.3729
		0.3486	0.3915			0.3477	0.3807
		0.3477	0.3807			0.3468	0.3700
		0.3382	0.3729			0.3378	0.3626
D27	5000~5300	0.3378	0.3626	D28	5000~5300	0.3374	0.3523
		0.3468	0.3700			0.3458	0.3593
		0.3458	0.3593			0.3449	0.3485
		0.3374	0.3523			0.3370	0.3420
D29	5000~5300	0.3370	0.3420	D30	5000~5300	0.3366	0.3317
		0.3449	0.3485			0.3440	0.3378
		0.3440	0.3378			0.3430	0.3271
		0.3366	0.3317			0.3362	0.3214

Please refer to CIE 1931 Chromaticity diagram



◆ Soldering Pad Dimensions:

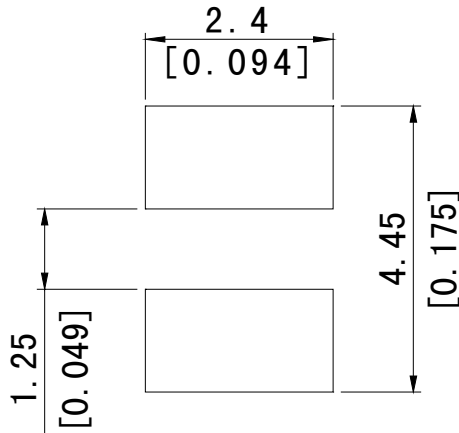

Unit:mm
Tolerance: ±0.2mm

◆ Soldering Conditions (Maximum allowable soldering conditions)

	Reflow Soldering		Hand Soldering	
	Lead Solder	Lead-free Solder	Temperature	Soldering time
Pre-heat	120 ~ 150°C	180 ~ 200°C	350°C Max. 3 sec. Max. (one time only)	
Pre-heat time	120 sec. Max.	120 sec. Max.		
Peak temperature	240°C Max.	260°C Max.		
Soldering time	10 sec. Max.	10 sec. Max.		
Condition	refer to Temperature - profile ①.	refer to Temperature - profile ②. (N ₂ reflow is recommended.)		

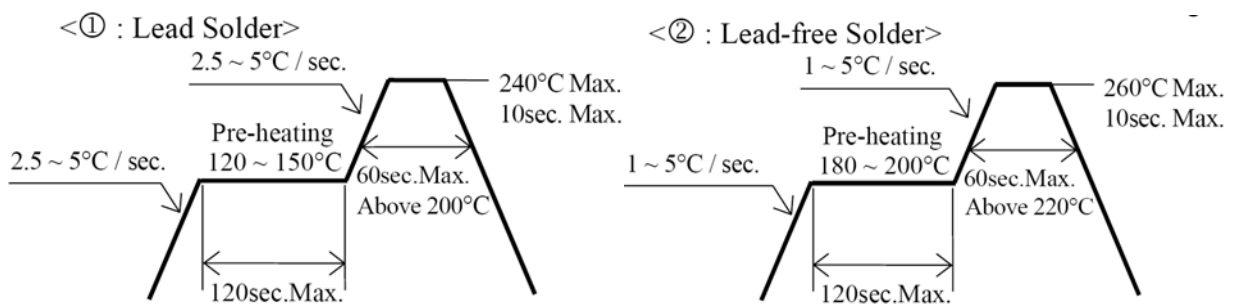

- Reflow soldering should not be done more than two times.
- Do not stress its resin while soldering.
- After soldering, do not warp the circuit board.
- Pay attention to electrostatic (ESD) .



Hebei I.T. (Shanghai) Co., Ltd.
Technical Data Sheet
Top View LED

Part No: PLCC2W6-0.1W

◆ Package Tape Specifications: (3000 ± 3 pcs/Reel)

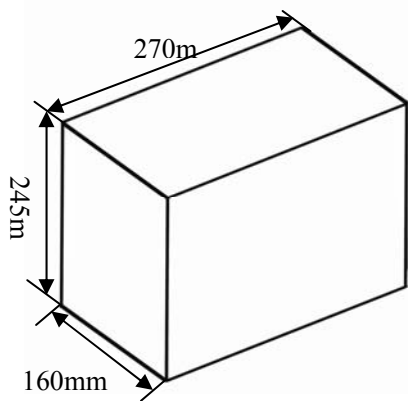
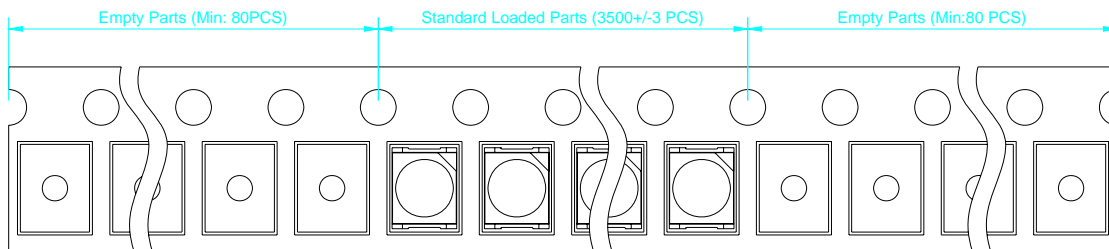
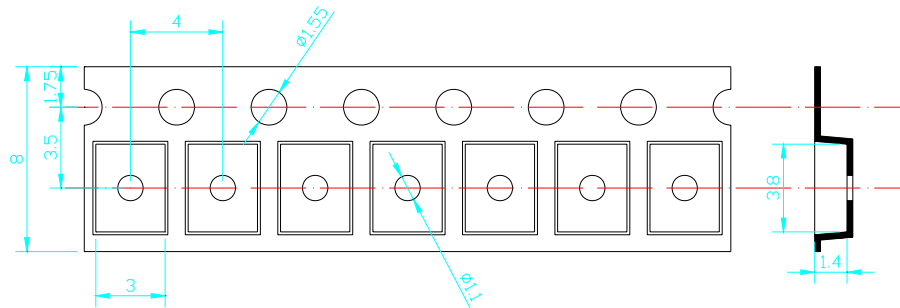

12 Reels in one Box

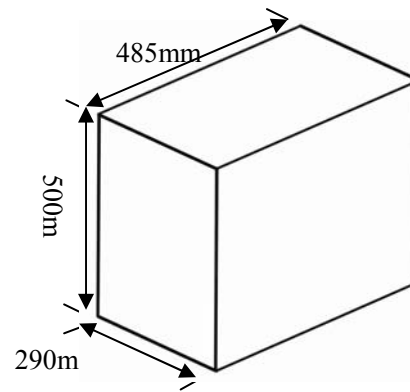

6 Boxes in one Carton



Hebei I.T. (Shanghai) Co., Ltd.

Technical Data Sheet

Top View LED

Part No: PLCC2W6-0.1W

◆ Typical Electro-Optical Characteristics Curves:

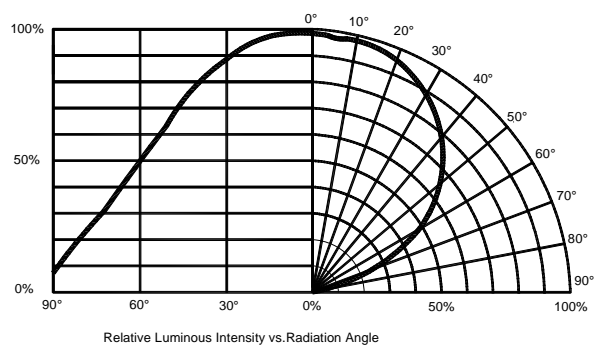
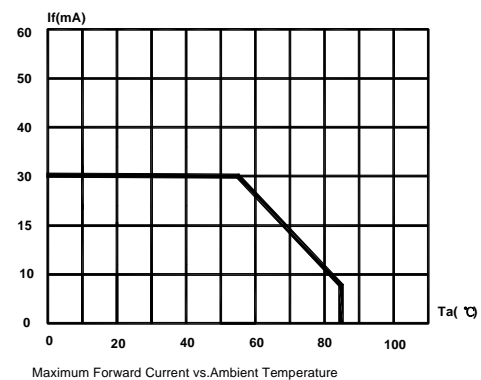
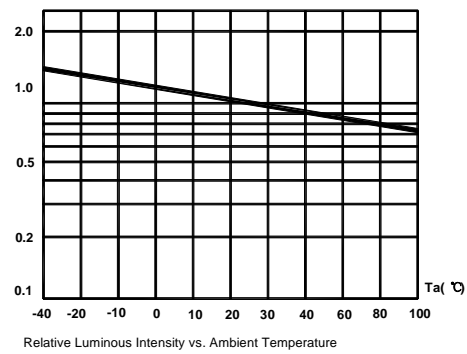
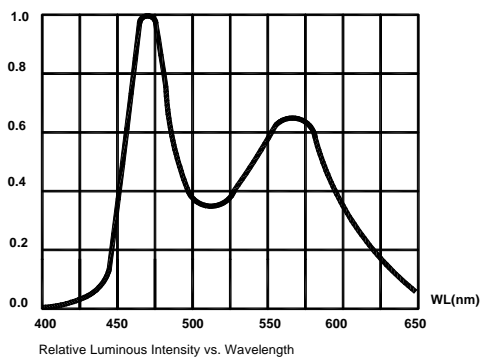
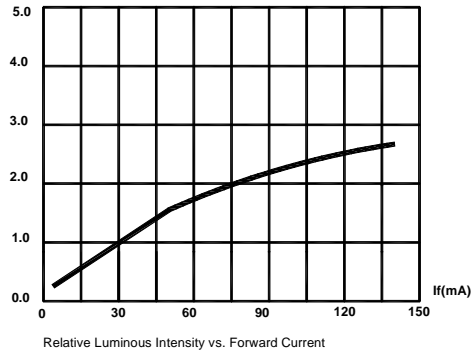
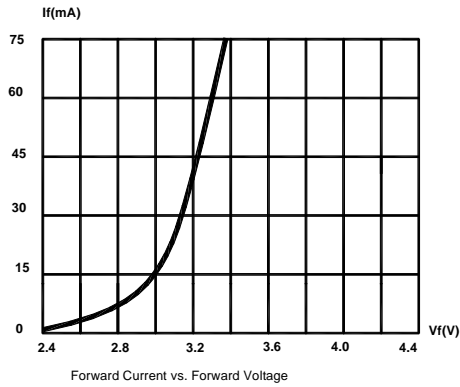



◆ Reliability

(1) Test Items and Conditions

Test Item	Standard Test Method	Test Conditions	Note	Number of Damaged
Reflow Soldering	JEITA ED-4701 300 301	A. $T_A=230\pm 5^{\circ}\text{C}$ TIME=30-60S B. $T_A=240\pm 5^{\circ}\text{C}$ TIME=110-120S C. $T_A=260\pm 5^{\circ}\text{C}$ TIME=10 \pm 1S D. $T_A=230\pm 5^{\circ}\text{C}$ TIME=30-60S	1 time	0/50
High Temperature Storage	JEITA ED-4701 200 201	$T_A=100\pm 5^{\circ}\text{C}$	1000 Hrs	0/50
Low Temperature Storage	JEITA ED-4701 200 202	$T_A=-40\pm 5^{\circ}\text{C}$	1000 Hrs	0/50
Temperature Humidity Storage	JEITA ED-4701 100 103	$T_A=85\pm 5^{\circ}\text{C}$, RH=90%RH	1000 Hrs	0/50
Thermal Shock Test	JEITA ED-4701 300 307	-40 $^{\circ}\text{C}$ ~ 100 $^{\circ}\text{C}$ 15min 10 Second 15 min	100 Cycles	0/50
Temperature Cycling Test	JEITA ED-4701 100 105	-40 $^{\circ}\text{C}$ ~ 25 $^{\circ}\text{C}$ ~100 $^{\circ}\text{C}$ ~25 $^{\circ}\text{C}$ 30min 15min 30min 15min	100 Cycles	0/50
Operating Life Test	MIL-STD-750:1026 MIL-STD-883:1005 JIS C 7021 :B-1	$T_A=25^{\circ}\text{C}$ $I_F=30\text{mA}$	1000 Hrs	0/50

(2) Criteria of judging the damage

Item	Symbol	Test Conditions	Criteria for Judgment	
			Min.	Max.
Forward Voltage	V_F	$I_F=30\text{ mA}$	---	Initial Data $\times 1.1$
Luminous Intensity	I_V	$I_F=30\text{ mA}$	Initial Data $\times 0.8$	---
Reverse Current	I_R	$V_R=5\text{V}$	---	$\leq 50\mu\text{A}$
Wave length	$\lambda D/\lambda P$	$I_F=\text{Test Current}$	/	Initial Data $\pm 2\text{nm}$
Appearance	/	View check	No mechanical damage	



◆ Cautions

1、 Package

When moisture is absorbed into the package it may vaporize and expand during soldering. There is a possibility that this can cause exfoliation of the contacts and damage to the optical characteristics of the LEDs. So the moisture proof package is used to keep moisture to a minimum in the package.

2、 Storage

Before opening the package: The LEDs should be kept at 5~30°C and 60%RH or less. The LEDs should be used within a year.

After opening the package: The LED must be used within 24 hours, else should be kept at 5~30°C and 30% RH or less. The LEDs should be used within 7days after opening the package. If unused LEDs remain, they should be stored in moisture proof packages, recommended to return the LEDs to the original moisture proof bag and to reseal the moisture proof bag again.

If the LEDs have exceeded the storage time, baking treatment should be performed more than 24 hours at $60 \pm 5^\circ\text{C}$.

3、 Soldering Iron

Each terminal is to the tip of soldering iron temperature less than 300°C for 3 seconds within once in less than the soldering iron capacity 25 W. Leave two seconds and more internally, and do soldering of each terminal. Be careful because the damage of the product is often started at the time of the hand solder.

4、 Repairing

Repairing should not be done after the LEDs have been soldered. When repairing is unavoidable, a double-head soldering iron should be used (as below figure). It should be confirmed beforehand whether the characteristics of the LEDs will or will not be damaged by repairing.

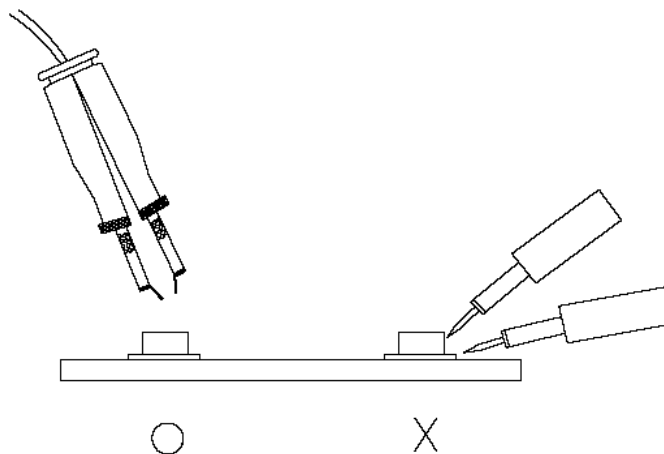

5、 The LED electrode sections are comprised of a gold plated. The gold surface may be affected by environments which contain corrosive gases and so on. Please avoid conditions which may cause the LED to corrode or discolor. This corrosion or discoloration may cause difficulty during soldering operations. It is recommended that the User use the LEDs as soon as possible.

6、 Please avoid rapid transitions in ambient temperature, especially in high humidity environments where condensation can occur.



7、Static Electricity

7.1、 These products are sensitive to static electricity charge, and users are required to handle with care. Particularly, if an current and or voltage which exceeds the Absolute Maximum Rating of Products is applied, the overflow in energy may cause damage to, or possibly result in electrical destruction of, the Products. The customer is requested to take adequate countermeasures against static electricity charge and surge when handling Products.

7.2、 Proper grounding of Products , use of conductive mat, conductive working uniform and shoes, and conductive containers are effective against static electricity and surge.

7.3、 Ground low-resistance areas where the product contacts, such as metal surfaces of the work platform, with a conductive mat (surface resistance 10^6 - $10^8 \Omega$).

7.4、 A tip of soldering iron is requested to be grounded. An ionizer should also be installed where risk of static generation is high.

◆ Notes:

1、 Above specification may be changed without notice. We will reserve authority on material change for above specification.

2、 When using this product, please observe the absolute maximum ratings and the instructions for the specification sheets. We assume no responsibility for any damage resulting from use of the product which does not comply with the instructions included in the specification sheets.