



5.0mm INFRARED EMITTING DIODE

520E940C

REV:A / 0

PACKAGE DIMENSIONS

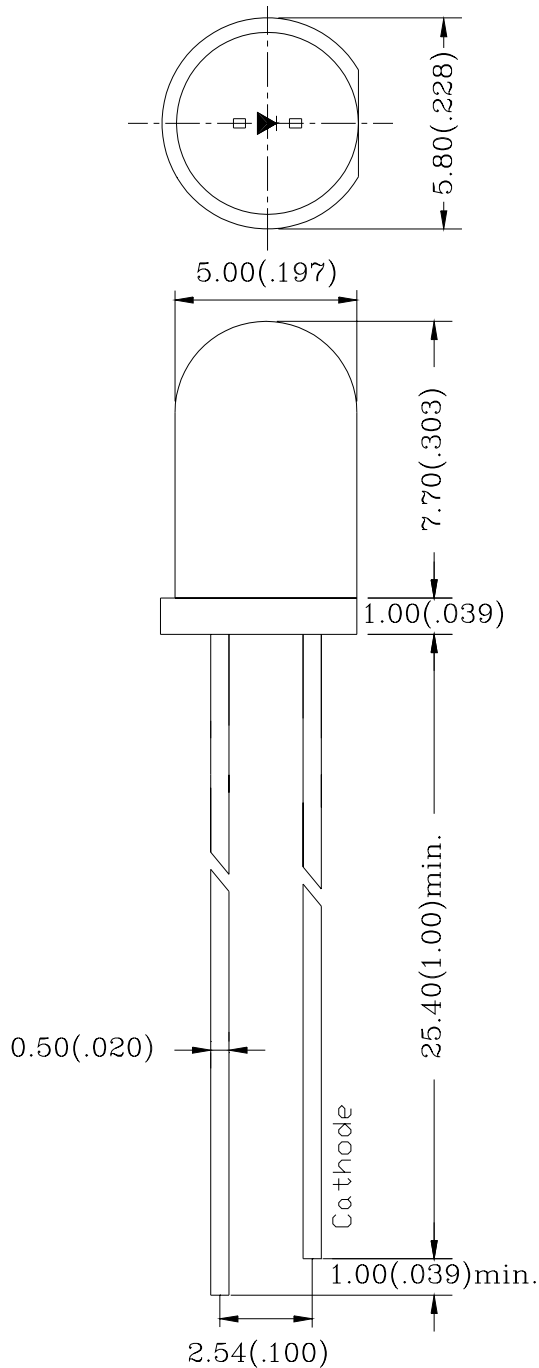

Note:

1. All Dimensions are in millimeters.
2. Tolerance is $\pm 0.25\text{mm}$ (0.010 ") Unless otherwise specified.
3. Protruded resin under flange is 1.5mm (0.059 ") max.
4. Lead spacing is measured where the leads emerge from the package.
5. Specification are subject to change without notice



5.0mm INFRARED EMITTING DIODE

520E940C

REV:A / 0

FEATURES

- * EXTRA HIGH RADIANT POWER AND RADIANT INTENSITY
- * LOW FORWARD VOLTAGE
- * SUITABLE FOR HIGH PULSE CURRENT OPERATION
- * HIGH RELIABILITY

CHIP MATERIALS

- * Dice Material : GaAlAs/GaAs
- * Lens Color : WATER CLEAR

ABSOLUTE MAXIMUM RATING : (Ta = 25°C)

SYMBOL	PARAMETER	INFRARED	UNIT
PD	Power Dissipation	100	mW
VR	Reverse Voltage	5	V
IF	Average Forward Current	100	mA
Topr	Operating Temperature Range	-35°C to 85°C	
Tstg	Storage Temperature Range	-35°C to 85°C	
Lead Soldering Temperature { 1.6mm(0.063 inch) From Body } 250°C ± 5°C for 3 Seconds			

ELECTRO-OPTICAL CHARACTERISTICS : (Ta = 25°C)

SYMBOL	PARAMETER	TEST CONDITION	MIN.	TYP.	MAX.	UNIT
VF	Forward Voltage	IF = 10mA IF = 50mA		1.2 1.4		V
IR	Reverse Current	VR = 5V			10	µA
λP	Peak Emission Wavelength	IF = 10mA		940		nm
2θ1/2	Half Intensity Angle	IF = 10mA		22		deg
IE	Radiant Intensity	IF = 10mA		30		mw/sr



5.0mm INFRARED EMITTING DIODE

520E940C

REV:A / 0

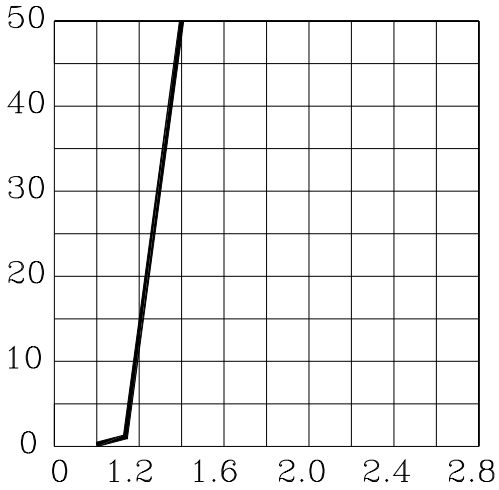

Forward Voltage VF(V)

Relative Luminous Intensity
Normalized of 20mA

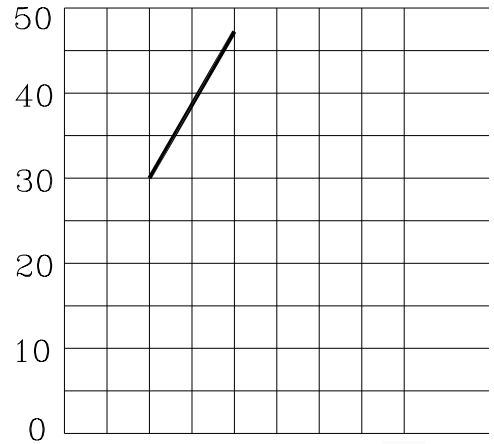

Forward Current(mA)

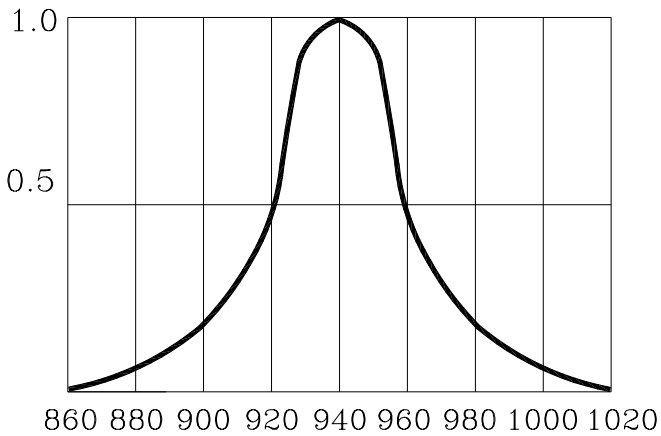

Wavelength(nm)
Spectral Distribution

Relative Radiant Intensity

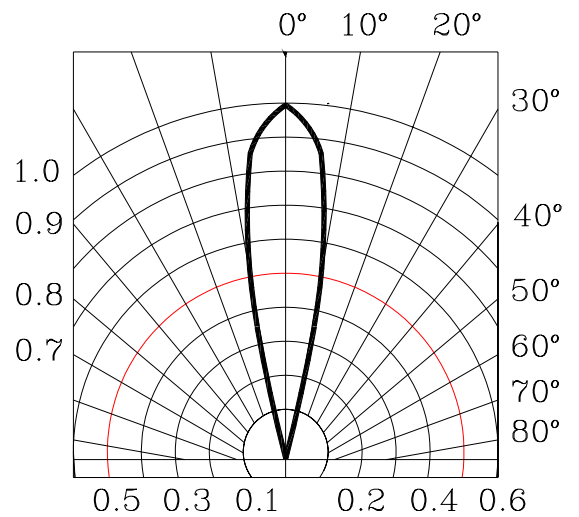

VIEW ANGLE